



- Ⓔ MANUAL DE INSTRUCCIONES ORIGINAL
- Ⓖ ORIGINAL USER GUIDE
- Ⓕ MANUEL ORIGINAL D'UTILISATION

**DEL-32**

**DEL-36**

**DEL-45**

**DEL-52**

**COMBI-25/32**

**COMBI-30/36**

**COMBI-36/52**

C/ Albuñol, par.250  
Pol. Ind. Juncaril,  
18220 ALBOLOTE (Granada) ESPAÑA  
Telf: (+34)958 490 410  
Fax: (+34) 958 466 645  
info@simasa.com  
www.simasa.com



## ÍNDICE

<b>1. GENERAL INFORMATION .....</b>	<b>4</b>
<b>2. GENERAL DESCRIPTION OF THE MACHINE.....</b>	<b>4</b>
<b>3. MACHINE.....</b>	<b>5</b>
<b>4. TRANSPORT.....</b>	<b>6</b>
<b>5. PICTOGRAMS.....</b>	<b>6</b>
<b>6. DELIVERY CONDITIONS .....</b>	<b>6</b>
6.1 INSTALLING THE PROTECTIVE VISOR .....	7
.....	<b>7</b>
6.2 BENDING PLATE .....	7
.....	8
<b>7. STARTING-UP AND USING THE MACHINE .....</b>	<b>8</b>
7.1 PLUGGING THE MACHINE TO THE ELECTRICITY .....	9
7.2 CONNECTING TO ELECTRICITY SOURCE.....	10
7.3 ELECTRICS SCHEME .....	11
7.4 SWITCHING PHASES TO ACHIEVE THE CORRECT BENDING DIRECTION FOR THE PLATE. ....	11
<b>8. BENDING WITH SUPPORT DEVICE OR MANDRELS. ....</b>	<b>12</b>
8.1 ADJUSTING THE BENDING ANGLE. ....	12
<b>9. MAKING A BEND .....</b>	<b>13</b>
<b>10. MAKING A CUT .....</b>	<b>14</b>
<b>11. SPECIAL ATTACHMENTS. ....</b>	<b>15</b>
<b>12. MAINTENANCE .....</b>	<b>17</b>
12.1 CHANGING THE BELTS .....	18
12.2 REPLACING THE BLADES (COMBI MODELS).....	19
<b>13. TOUBLE SHOOTING. ....</b>	<b>20</b>
<b>14. SAFETY RECOMMENDATIONS.....</b>	<b>21</b>
<b>15. WARRANTY .....</b>	<b>22</b>
<b>16. DECALARATIONS ON NOISE .....</b>	<b>22</b>
<b>17. DECLARATIONS ON MECHANIAL VIBRATIONS .....</b>	<b>22</b>
<b>18. SPARE PARTS .....</b>	<b>22</b>
<b>19. ENVIRONMENT PROTECTION.....</b>	<b>22</b>

## 1. GENERAL INFORMATION

**WARNING: Please read and understand perfectly the present instruction before using the machine.**

SIMA S.A. thanks you for your trust in our products and for purchasing the BENDING OR COMBINED ELECTRICAL CUTTING/BENDING MACHINE.

This manual provides you with the necessary instructions to start, use, maintain and in your case, repair of the present machine. All aspects as far as the safety and health of the users is concerned have been stated.

Respecting all instructions and recommendations guarantees safety and low maintenance.

As such, reading this manual carefully is compulsory for any person responsible for the use, maintenance or repair of this machine.

**It is recommended to have always this manual in an easily accessible place where the machine is being**

## 2. GENERAL DESCRIPTION OF THE MACHINE

- The DEL bending machines have been manufactured to bend flat and reinforced steel bars used for construction and passive steel armatures for structural concrete. The bending operation is done in cold using mandrills to guarantee the bending interior diameter is conforming to the European norms.

- The combined machines bending/cutting models COMBI are designed to bend as well as cut steel bars. The cutting tools are two blades, one fixed and one moving. The cutting operation is done manually by pushing the bar on the roller, dropping the bar into the cutting throat, lowering the protection guard and pressing the pedal.

**Any other use of this machine is considered inadequate and can be dangerous. Thus, this is completely prohibited.**

- The machine is equipped with an electrical auto-ventilated motor-brake
- The reducer is the main element of the machine. It is responsible for transmitting the needed energy to carry out the steel bars bending.
- The machine is operated by an electrical motor that passes the movement, by a transmission to the bending mechanism in which the different mandrills are mounted.
- The bending plate can be selected to work in two different directions, left or right, by changing the direction of rotation in the electrical control panel.
- The bending angle can be decided by inserting the pivot in the bending plate. For a more precise bending, the ruler can be accurately adjusted by its handle.
- The commands panel is endowed with polyester, electrical knobs easily identified by pictograms.
- The machine is equipped with shutdown and backward movement buttons to facilitate its manoeuvre. The emergency knobs on both sides of the machine can be used in case of danger or incorrect manoeuvres.
- The general bars bending manoeuvre is performed in low-voltage (24V) according to the European standards.
- The original equipment (bolts, mandrels bending square) are heat-treated to withstand the tough type of work the machine performs.
- The machine is furnished with a pedal to confirm and execute the manoeuvre, thus avoiding the upper parts to be trapped while the machine is running.
- The work area is protected by a safety guard to limit possible accidents. This guard is transparent to allow observation of the material being bent, avoiding getting to the upper parts of the bending area.
- The machine is equipped with wheels to facilitate their movement.
- The machine is painted in oven with a highly resistance, anti-corrosion epoxy polyester paint.
- The original, electrical equipment is in conformity with the EC safety norms.
- The COMBI model is supplied with a cutting jaw with a safety metal guard connected to an electrical protection system. When this safety guard is lifted, the machine stops working.

### 3. MACHINE

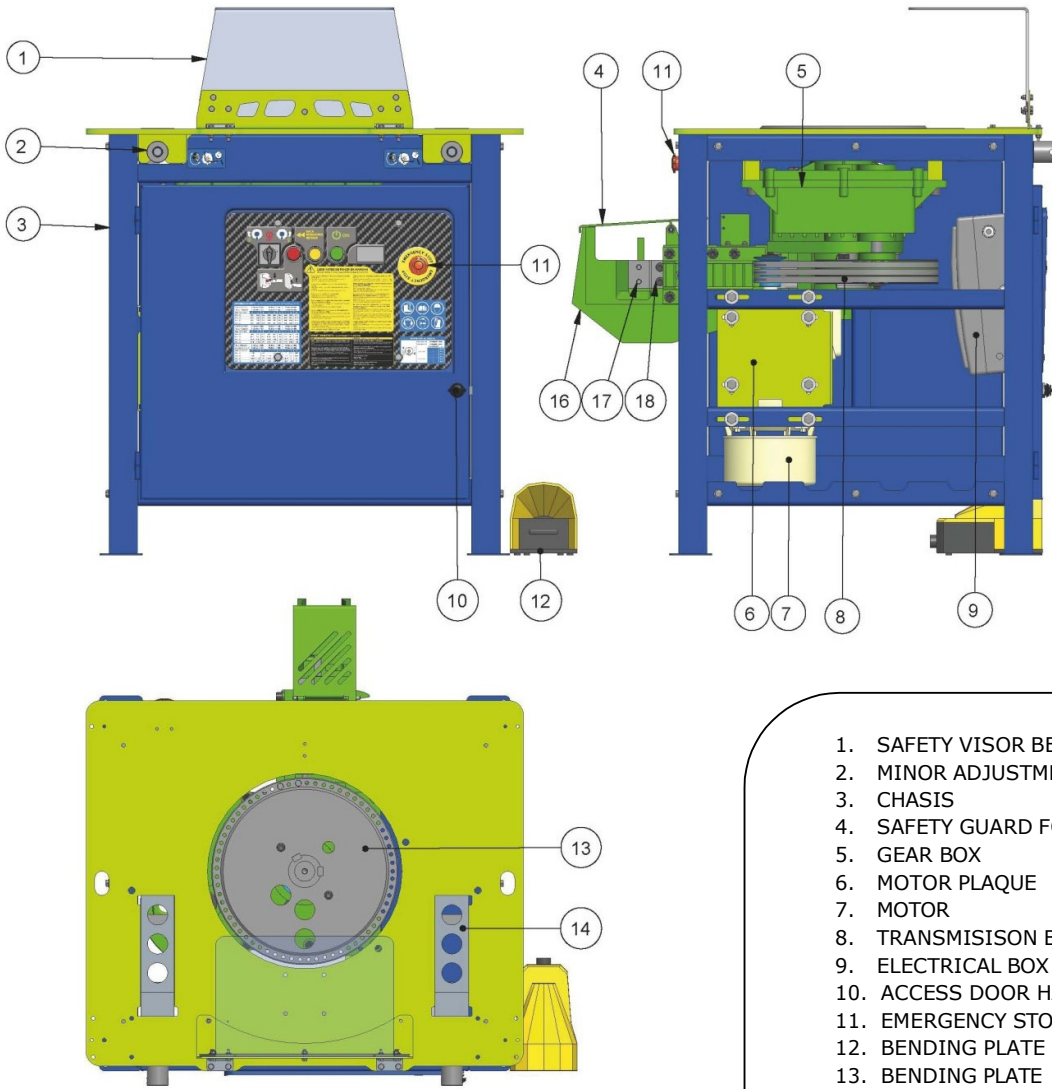

1. SAFETY VISOR BENDING PLATE
2. MINOR ADJUSTMENT HANDLE
3. CHASIS
4. SAFETY GUARD FOR CUTTING HEAD
5. GEAR BOX
6. MOTOR PLAQUE
7. MOTOR
8. TRANSMISISON BELTS
9. ELECTRICAL BOX
10. ACCESS DOOR HANDLE
11. EMERGENCY STOP
12. BENDING PLATE FOOT PEDAL
13. BENDING PLATE
14. SIDE MANDREL ADJUSTMENT
15. ELECTRICAL SOCKET
16. MCUTTING HEAD
17. FIXED CUTTING BLADE
18. MOVING CUTTING BLADE



1. INVERSE SWITCH
2. OVERLOAD PROTECTION WARNING LIGHT
3. RETURN SWITCH
4. ON LIGHT
5. VOLTMETER
6. AMPMETER
7. EMERGENCY STOP

### 4. TRANSPORT

For a safe transport of the machine, please follow the following instructions:

The Bending and Combined machines are fitted with holes in the working table to be lifted with cranes through chains or cables. The means of transport used must be safe.

**IMPORTANT:** During the transport of the machine, the latter should never be reversed nor be put on either side. The machine is only to rest on its four feet.



### 5. PICTOGRAMS

Pictograms included in the machine entail the following:



USE SAFETY FOOTWEAR



USE HELMET AND EYE AND EAR DEFENDERS









READ INSTRUCTIONS MANUAL



USE SAFETY GLOVES

### 6. DELIVERY CONDITIONS

SIMA bending and combined machines are delivered individually packed on a reinforced pallet. The following items are sent together with the machine:

											
			Ø60	Ø100	Ø140	Ø160	Ø200				
DEL-32	1	4	4	1	1			1	1	1	2
DEL-36	1	4	4	1	1	1		1	1	1	2
DEL-45	1	4	4	1	1	1		1	1	1	2
DEL-52	1	4	4	1	1	1	1	1	1	1	2
COMBI-25/32	1	4	4	1	1			1	1	1	2
COMBI-30/36	1	4	4	1	1	1		1	1	1	2
COMBI-36/52	1	4	4	1	1	1	1	1	1	1	2

## 6.1 INSTALLING THE PROTECTIVE VISOR

For transport reasons, the plate safety guard is disassembled. Before using the machine, the plate safety guard should be mounted. The latter presses a security microswitch and if it is not installed correctly the machine will not start.

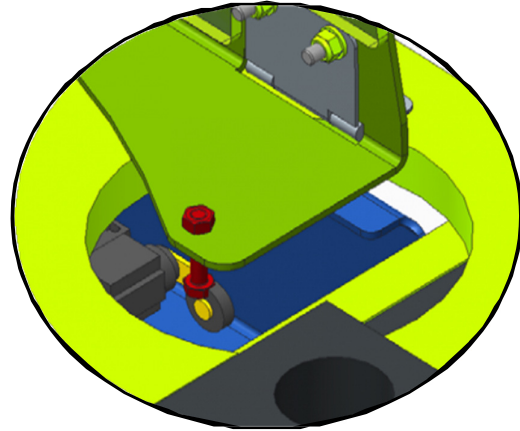
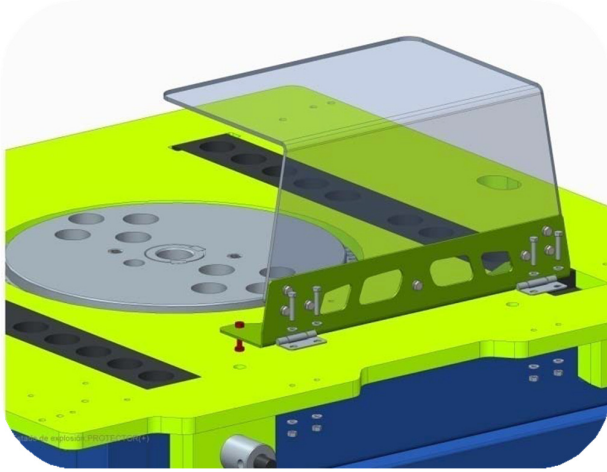

## 6.2 BENDING PLATE

Depending on the model that you have purchased the bending plate will have different holes for different purposes.

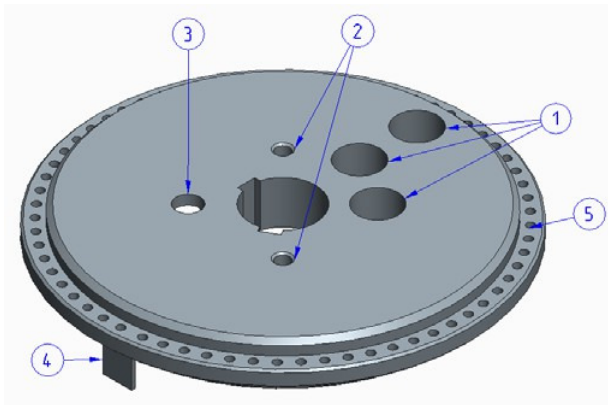

1. Holes for bending mandrels. Depending on the size of the rebar the mandrels will go into different holes.
2. Screw holes for fixing the optional large diameter kits
3. Screw hole for spiral kit.
4. End of bend reference point.
5. Holes for bending pins.

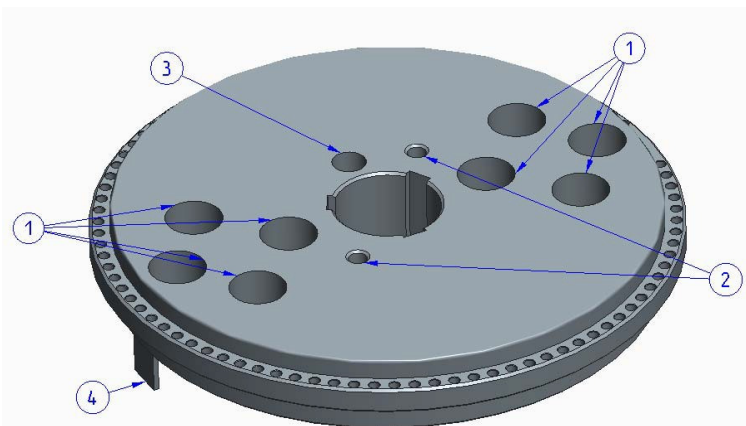

### 6.3 ANGLE INVERSION AND SELECTION PIVOT

The inversion pivot (**Fig. P**) It is used to select the plate rotation angle. Depending on the rotation direction of the plate that we choose, we have to insert the pivot in different sectors relative to the **S1 and S2 sensor**

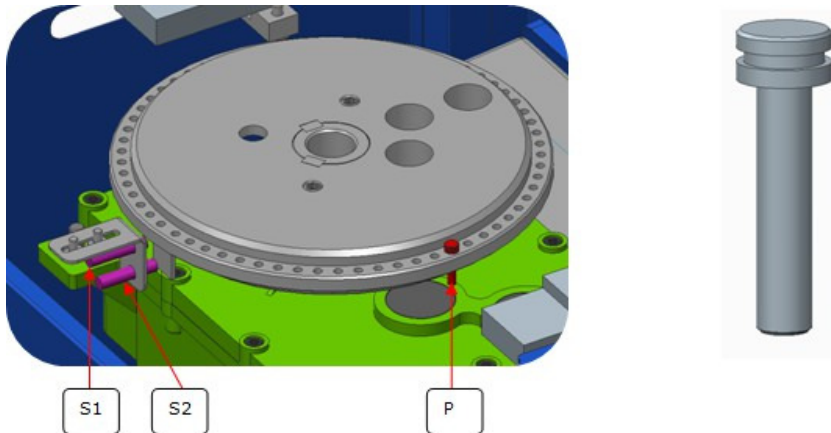

Sensor S1, is to stop the bending plate when the pivot passes over it.

Sensor S2, is to stop the bending plate when it returns to its original position.

## 7. STARTING-UP AND USING THE MACHINE

**WARNING:** All safety recommendations must be followed, either the ones mentioned in the present user manual or those complying with all labour risks prevention norms in every location.

**WHEELWORK:** SIMA bending and combined machines do not need any wheelwork operations as they are specially designed to obtain the maximum performance from start.

#### **NORMAL USE OF THE MACHINE:**

The bending machines have been designed for bending and cutting flat and reinforced steel bars for use in the structure and other construction. Each other use that has not been expressly indicated is considered abnormal. Any tool or accessory added or amended without written authorization from the manufacturer is considered inappropriate and dangerous. If any damage or injury is caused as a result thereof or by misuse of the machine, SIMA S.A. exempts all responsibility as manufacturer. The machine must be installed on a plane, firm and horizontal surface and the ground should not be soft.



**This machine MUST NOT BE USED IN THE RAIN. Cover with waterproof materials. If the machine has been exposed in the rain check before connecting the electrical parts are not wet. Always work with good lighting conditions.**



## 7.1 PLUGGING THE MACHINE TO THE ELECTRICITY

The extension cable used to feed the machine needs to have a minimum section of 4x2.5 mm up to 25 meters long. For a superior distance 4x4 mm<sup>2</sup> can be used. In one of its ends, it is needed to connect a base normalised aerial of 3P+T or 3P+N+T compatible with the machine switch and in the other end, one normalised aerial pin of 3P+T ó 3P+N+T compatible with switchboard exit.



**Machines with electrical motor should always be connected to a normalised switchboard that disposes of a magneto-thermal switch and a differential in accordance with the characteristics of the motor:**

3Kw / 4 HP, three phase at 400V, 15A magneto-thermal and 15A/300mA differential.

3Kw / 4 HP, three phase at 230V, 20A magneto-thermal and 20A/300mA differential.

The machine electrical tension is visible on the voltage indication next to the top of engine terminals and on the machine characteristics plate.

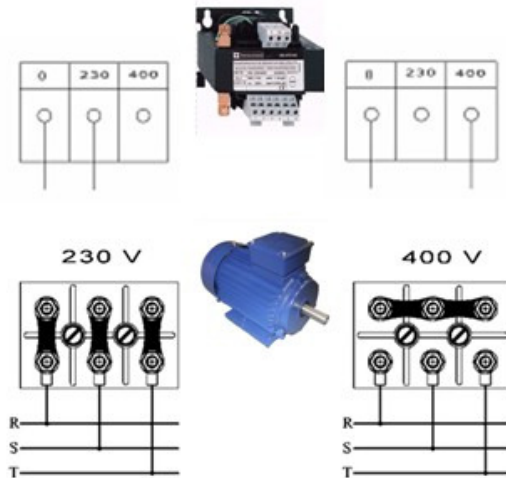

**Do not plug the machine to the electricity if you are not sure of the available electrical tension. If the tension is not correct, the engine will undergo irreparable harm or out of service.**



**Do not perform any electrical work on the machine unless it is disconnected from the mains.**



**VERY IMPORTANT: Earth should always be connected before the machine is switched on.**

### 7.2 CONNECTING TO ELECTRICITY SOURCE.

The machine has a display so that the user can see the voltaje supplied to the machine before the voltaje reached the electrical components and causes any damage.

To connect the machine do the following

1. Open the door and connect the socket to the electrical box socket .This way the electricity will not reach the motor and you can see the voltage coming into the machine.



**IMPORTANT:** The transformer has a tolerance of  $\pm 10\%$  of the stated voltage capability of the machine. If this limit is passed then it will damage the transformer.

**400v machine = 380V min / Max 430V max**

**230V machine = 210V min / Max 250V max**

2. Select a bending direction on the electrical panel and the green light will come on.
3. Depress the pedal to start to bend and see which way the plate is bending



**Position 0.** Machine disconnected

**Position 1.** Machine connected in anti clockwise.

**Position 2.** Machine connected in clockwise position.



**When connecting the machine, make sure the machine is turning in the way the sticker indicates, this will avoid accidents with the accessories on the bending plate.**

**If it doesn't turn the right way please change the phases.**

## 7.3 ELECTRICS SCHEME

### MANUAL EMERGENCY RETURN OF BENDING PLATE

If during the bend you want to stop the process press the RETURN button and use the pedal to return to a previous position or to the start.



### 7.4 SWITCHING PHASES TO ACHIEVE THE CORRECT BENDING DIRECTION FOR THE PLATE.

To change the direction of the bend you will have to open the connecting socket and interchange the wires as show in the image.

3P +T



3P+N+T



## 8. BENDING WITH SUPPORT DEVICE OR MANDRELS.

The bending support accessory is used to bend bars up to 16mm to support the bar all the way to the bending area. This will help stop the bar from flexing and deforming.

Mandrels are used for bars thicker than 16mm as the rigidity is sufficient that there will be no deformation.

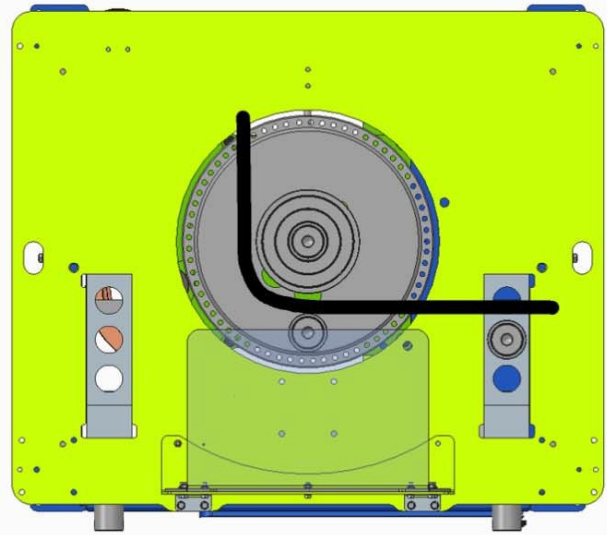
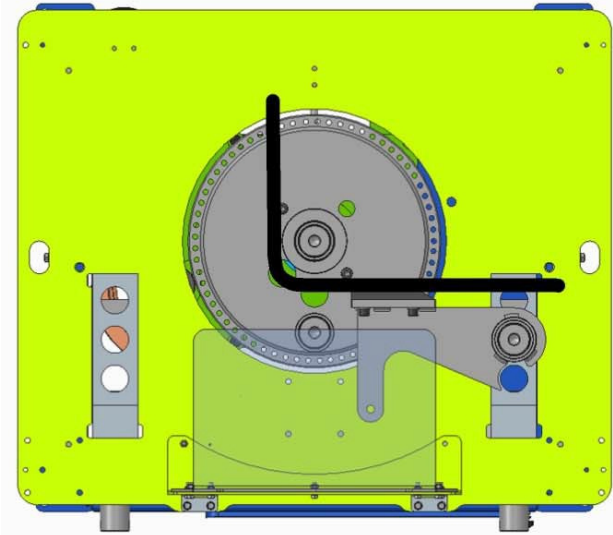

### 8.1 ADJUSTING THE BENDING ANGLE.

If you haven't achieved the bending angle you require with the pin and you need to make a small adjustment you can use the silver metal handles on the side of the machine to move the support mandrels.

Turn the handle to push the mandrel further away to make a tighter angle and bring it towards to make a more open angle.

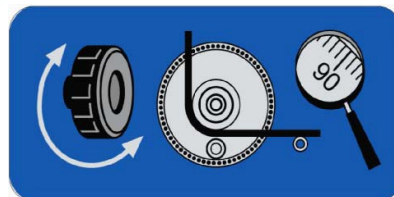
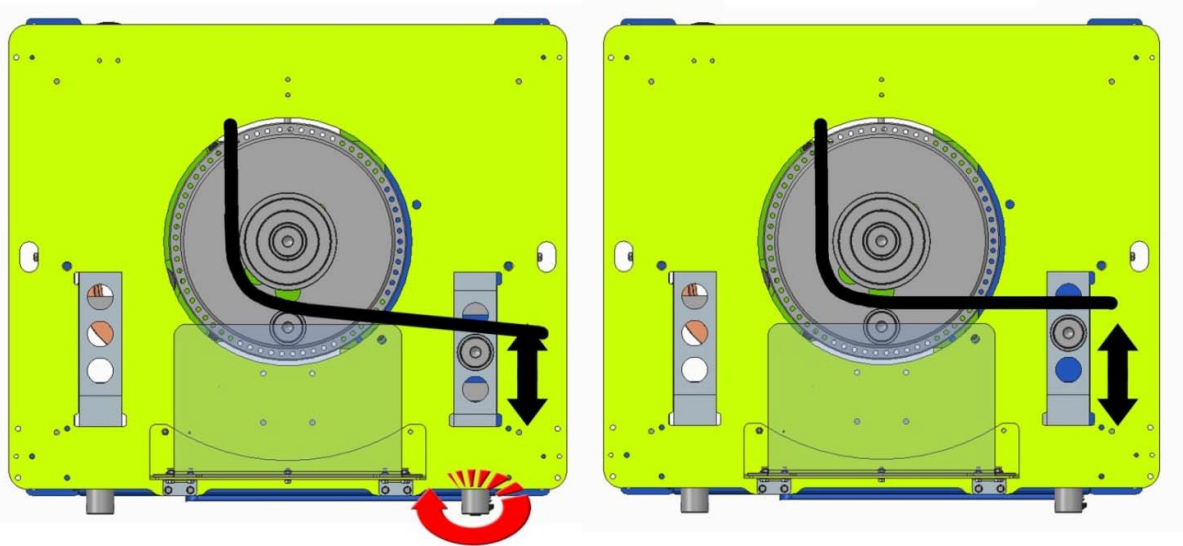

## 9. MAKING A BEND



**Before starting to bend a rebar make some bends without any accessories on the machine until you are comfortable with the movement.**

1. Divide the bending plate into 4 imaginary 90degree sections.
2. Select bending direction with the control panel button.
3. Insert the plate pin to the left of 0 degrees so achieve an angle of 90.
4. Step on the pedal and don't lift off. The bending plate will move until the pin reaches the inversión switch.
5. To make the plate return lift your foot off the pedal and press again and the plate will return.

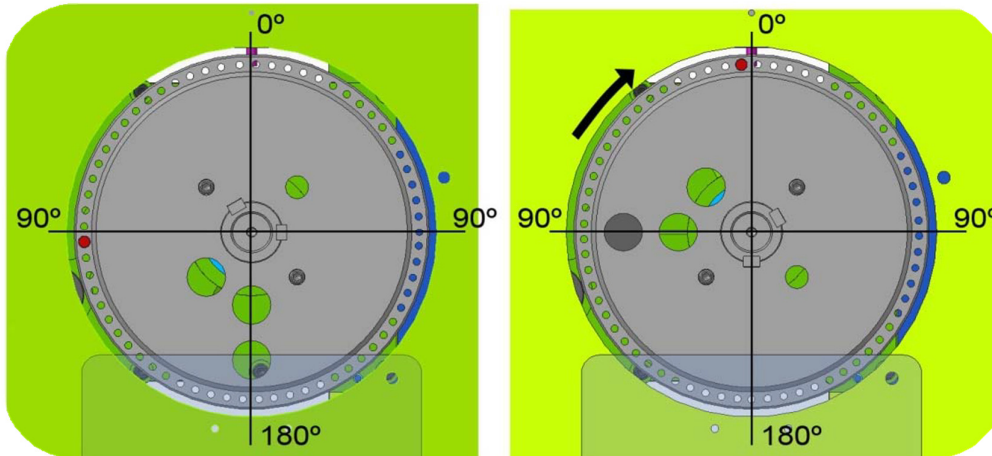



## 10. MAKING A CUT.



Remove all the bolts, shells and pivots that are on the bending plate.



Never use the machine for cutting and bending at the same time as this presents a great risk to accidents and an over effort for the motor and the reducer causing serious damages.

### CONTINUOUS CUTTING

Remove all the bolts, shells and pivots that are on the bending plate and press the pedal.

### DISCONTINUOUS CUTTING

To obtain a cutting in cycles, you can prepare the machine, placing an inversion pivot **P** right in the interior, small hole in the end of course of the plate exactly when the blades close.

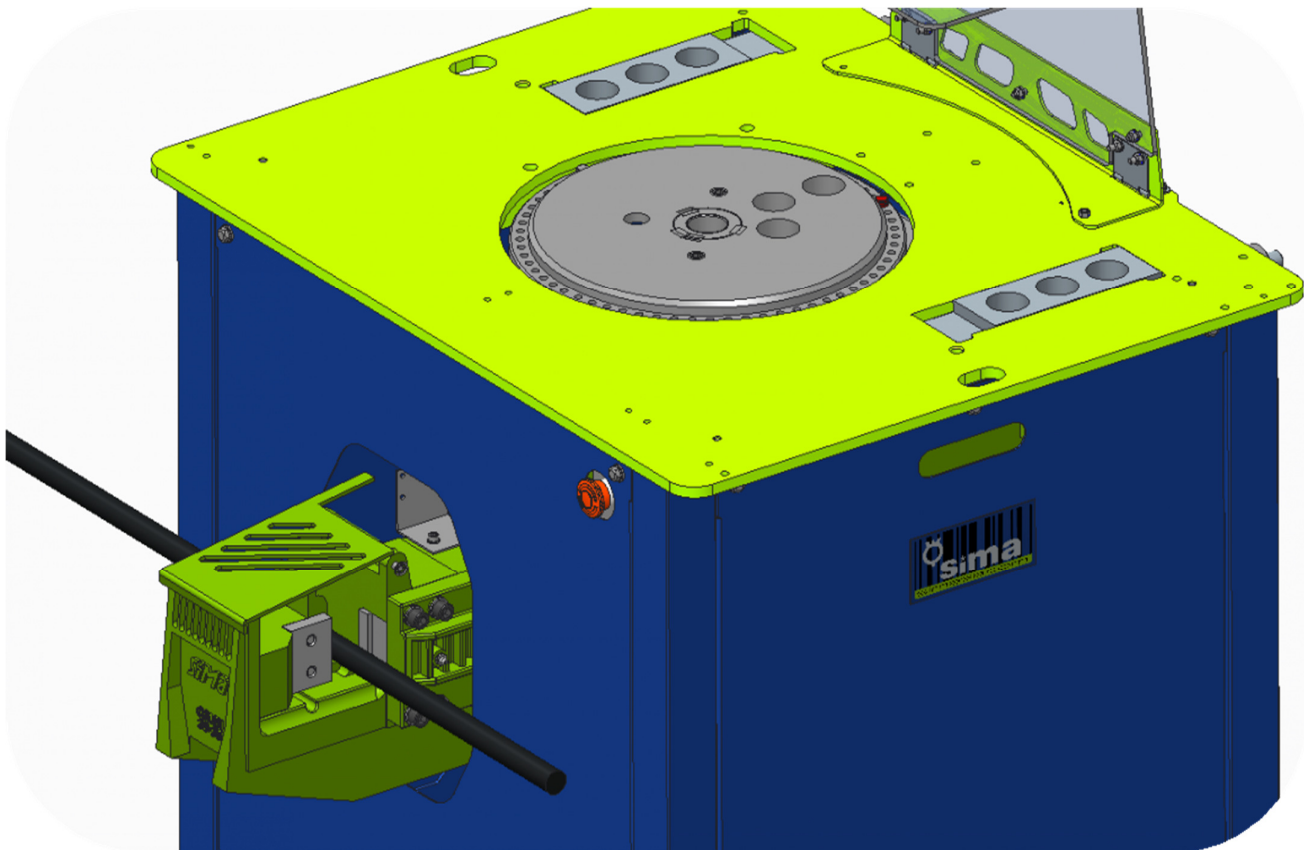

## 11. SPECIAL ATTACHMENTS.

The bending and combined machines can use certain accessories that do not come included with the machine. These attachments perform different functions.

**1. STIRRUP DEVICE :** This device is for making stirrups.

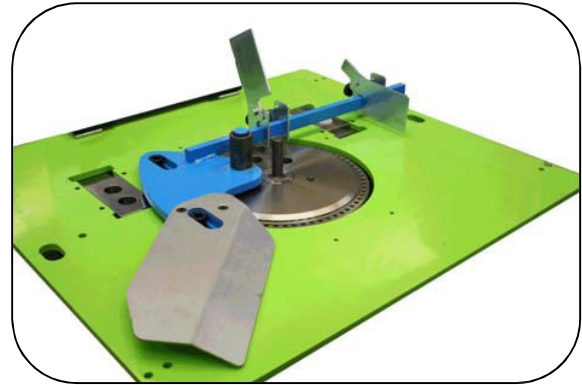

**2. SPIRAL DEVICE:** This device is used to make spiral formations with rebar.. Bars of diameter 6mm to 20mm can be used.

**3. BIG DIAMETER DEVICE :** This device aids in complying with EU safety regulations for large bends. It is composed of a series of accessories and mandrels with a minimum radius for each bar diameter.

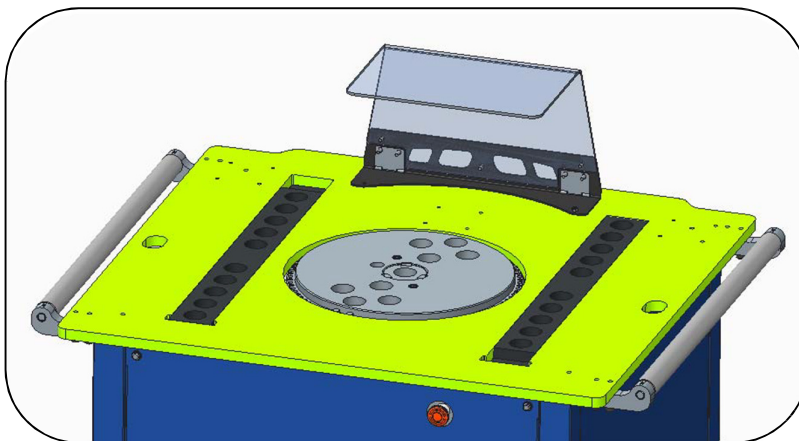
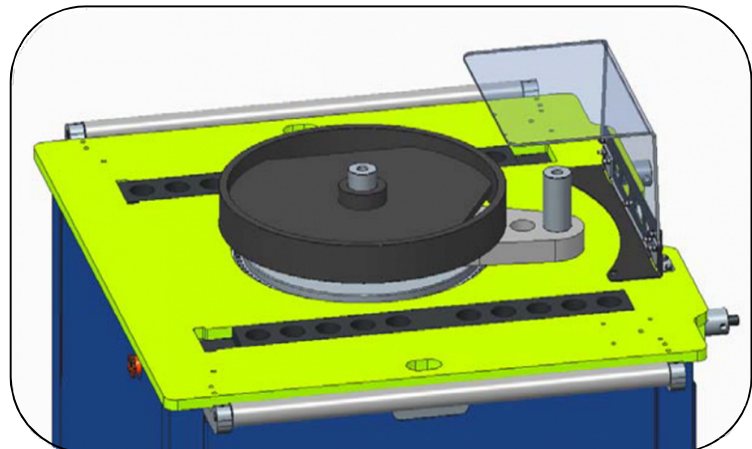

**4. ROLLER SUPPLY BENCH:** This is designed to help the bars slide towards the machine and protect the deterioration of the table through constant contact with the rebar.

5. **ROLLER FEED TABLES:** Designed to support bars before they are fed into the machines.



6. **MANDREL EXTRACTOR:** Designed to help remove the mandrels.







## 12. MAINTENANCE.

- 1 First oil change after 1000 hours of use if mineral oil is used and then again after 3000/4000 hours if the oil used is synthetic or after 3 years of use if these hours aren't reached. If synthetic oil is used change oil after 20,000 hours.
- 2 Grease the holes where the pins and mandrels go and also the bottom of the pins and mandrels, this will also help avoid build up of rust.
- 3 At the end of the day disconnect the machine.
- 4 Cover the machine at night to protect from rain.
- 5 When possible remove debris from the inside of the machine.
- 6 Clean the exterior and grease pins and mandrels frequently..
- 7 Check the blades on the cutter (**every 8 days of use**) to see if they need changing.
- 8 Check oil level in the gear box (**every month**) if the level has gone down be sure to fill up.

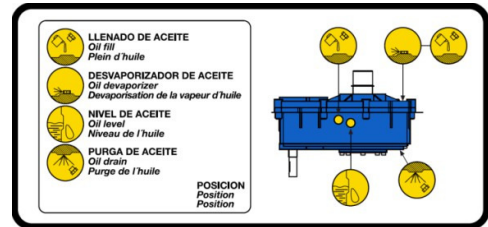

- 9 For COMBI models, there are two greasing points that should be greased every 20 days.

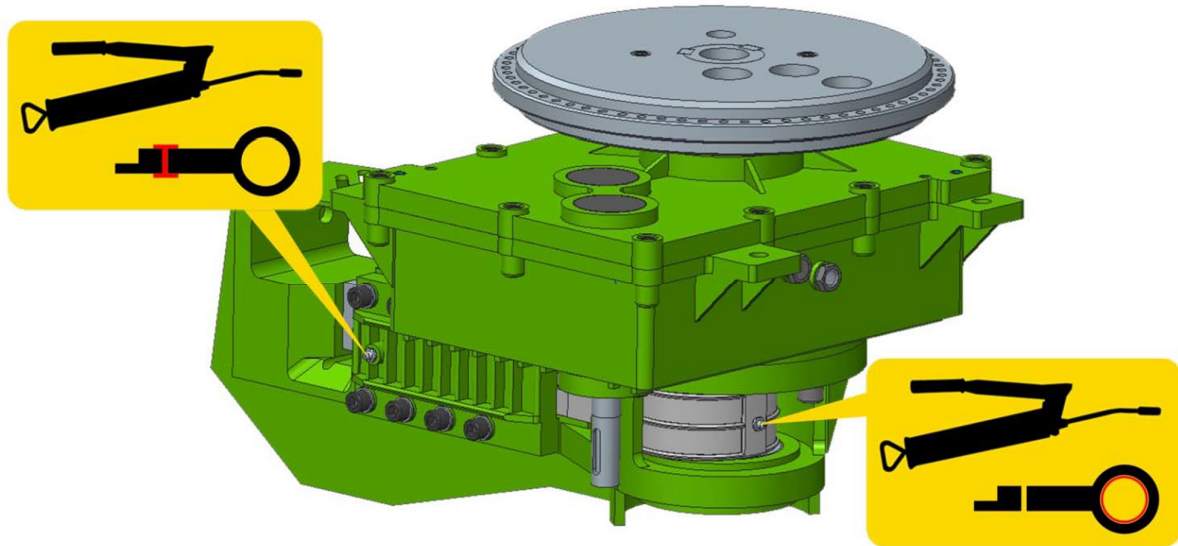

## 12.1 CHANGING THE BELTS .

The machines leave the factory with the belts correctly tightened, however it is possible that after a few days of work the belts become loose. To tighten the belts again the process is the same.

1. Make sure the machine is disconnected from the electricity supply.
2. Remove the side panel of the machine.
3. Loosen the 4 bolts that hold the platform to the guide.
4. Tighten the belt with the tightening mechanism.
5. Retighten the bolts.
6. Replace the side panel of the machine.

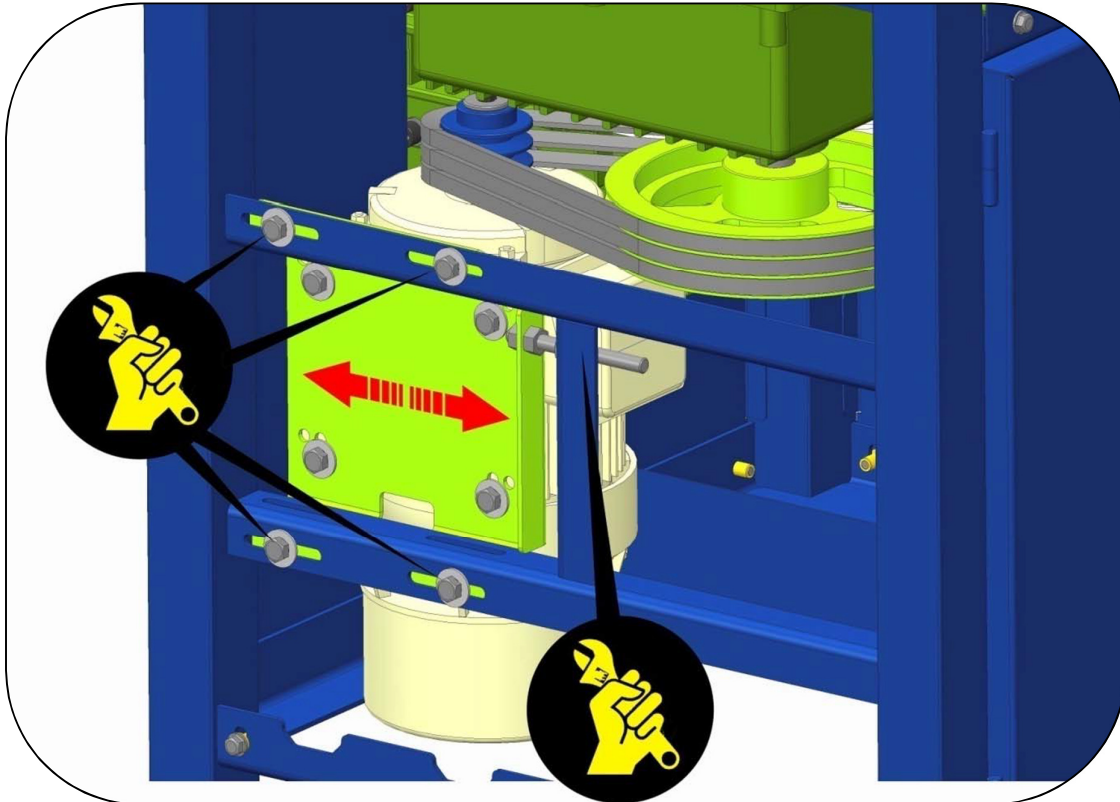

## 12.2 REPLACING THE BLADES (COMBI MODELS)

If any of the cutting blades is damaged, replace them as to the following procedure:

**1 CHANGING THE FIXED BLADE.** Make sure the machine is unplugged from electricity. Lift the safety guard off the blades. Afterwards, remove the screws and rotate the blade for a new cutting session or substitute it with a new blade if necessary.

**2 CHANGING THE MOVEABLE BLADE.** To change this blade, it is necessary that the connecting rod is displaced outside its housing. Operate in the following way: with the machine switched on and the inversion pivot of the bending plate removed from its position, press the pedal and observe the movement of the blade. When we see that the blade is outside its housing, we depress the pedal. Right after, we unplug the machine from the electricity to avoid any accident. In this way, we can reach the screws that fix the blade. Remove the screws of the blade for a new cutting or substitute it with a new blade if necessary.

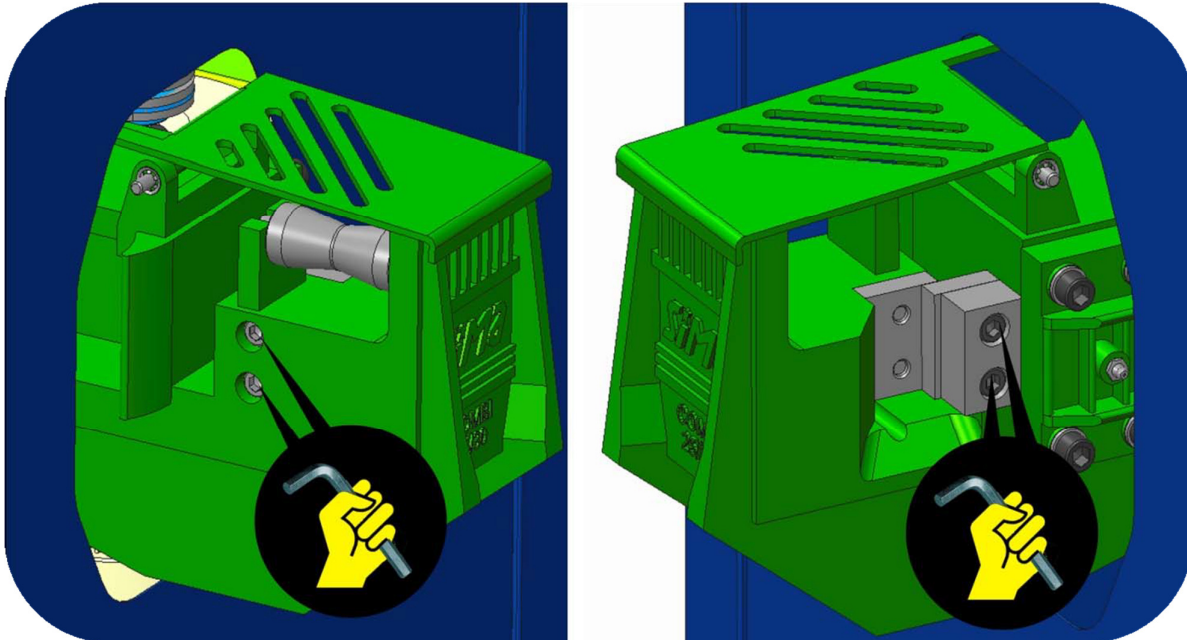

13. **TOUBLE SHOOTING.**

PROBLEM	POSSIBLE CAUSE	SOLUTION
NOT ENOUGH POWER TO CUT OF BEND.	LOOSE OR DAMAGED BELTS	TIGHTEN OR REPLACE BELTS
	DAMAGED BLADES	REPLACE BLADES OR CHANGE CUTTING SIDE
	MOTOR NOT RECEIVING CORRECT CURRENT	CHECK VOLTAGE
THE BENDING PLATE DOESN 'T RETURN TO ITS ORIGINAL POSITION AFTER THE BEND IS COMPLETE	DEFCTIVE INDUCTIVE SENSOR	CHECK THE SENSOR (1 OPEN, 0 CLOSED). REPLACE IF DAMAGED
NOT ENOUGH OR UN CURRENT REACHING THE MACHINE, THE PILOT LIGHT DOESN 'T COME ON	LACK OF CURRENT REACHING THE ELECTRICAL JUNCTION BOX	CHECK SITE JUNCTION BOX TO MAKE SURE ELECTRICITY IS BEING PRODUCED
	MAIN ELECTRICITY DOWN	CHECK THE CURRENT FROM THE MAINS
	FUSE HAS BLOWN ON THE JUNCTION BOX	REARM THE FUSE
	CABLE IN BAD STATE	REPLACE THE CABLES
THE PILOT LIGHT IS ON BUT THE MACHINE DOESN 'T WORK	THE MACHINE ISN 'T CORRECTLY CONNECTED	CHECK THAT ALL PHASES ARE COMPLETE. CHECK THE FUSE IN THE MACHINES ELECTRICAL BOX
	EMERGENCY STOP BUTTON IS DEPRESSED	RELEASE EMERGENCY STOP
	SECURITY FEATURES ARE ACTIVATED	MAKE SURE ALL DOORS, EMERGENCY STOP BUTTONS AND PLASTIC TABLE TOP GUARD ARE IN CORRECT POSITION
230V OR 400V CONNECTION. THE CONNECTION IS CORRECT BUT THE MACHINE DOESN 'T HAVE ENOUGH POWER.	UNSTABLE ELECTRICITY SUPPLY	CHECK THE ELECTRICITY SUPPLY IF THE VOLTAGE IS INFERIOR TO 230V OR 400V THE MACHINE WON'T WORK. A TENSION STABILISER IS RECCOMENDED
THE MACHINE LOSES OIL THROUGH THE GEAR BOX	RUBBER WASHER DETERIORATED.	REPLACE RUBBER WASHER
WHEN BEND IS FINISHED THE PLATE DOESN 'T STOP AT THE ORIGINAL POSITION	DEFCTIVE INDUCTIVE SENSOR	CHECK THE SENSOR (1 OPEN, 0 CLOSED). REPLACE IF DAMAGED
THE BENDING PLATE DOESNT STOP IMMEDIATELY WHEN THE PEDAL IS RELEASED	THE MOTOR BRAKE HAS WORN	CHECK THE MOTOR BRAKE AND TIGHTEN THE SPRINGS LEAVING A UNIFORM GAP BETWEEN THE DISC AND THE PLATE OF .3 TO .4MM.
	THE MOTOR BRAKE IS NOT OPERATIONAL	REPLACE THE MOTOR BRAKE
STRANGE NOISE FROM WITHIN THE GEARBOX	DETERIORATION OF SOME OF THE INTERNAL COMPONENTS	DISMANTLE THE GEARBOX AND CHECK BEARINGS AND GROOVES. REPLACED DAMAGED ELEMENTS
STRANGE NOISE FORM THE MOTOR	MISFUNCION OF ONE OF ITS COMPONENTS	FIND OUT THE SOURCE OF THE NOISE AND REPAIR

## 14. SAFETY RECOMMENDATIONS

Bending and combined (bending/cutting) machines should be used by trained people or people familiarized with their operation.

- Before starting up the machine please read the instructions and make sure safety norms are respected. Learn how to stop the machine in a fast and safe way.
- Place the machine on a plane surface. Connect the machine to the electricity only when you are sure of its stability.
- Start the machine only when you have mounted the safety guards that come with the machine.
- It is recommended to use safety glasses, safety boots, gloves etc. Please always use approved materials.
- Always use Individual Protection Equipment (IPE) in accordance with the type of work you are effectuating. Prohibit strangers to access the place of work of the machine.

Work clothes are not supposed to have loose articles that can cling into movable parts of the machine.

When you have to move the machine, unplug the electricity cables and block the moving parts of the machine.

Always keep protection elements and the safety guards in their correct positions.

**Attention:** Before placing the bolts, mandrills and the bending squares, check the direction of rotation of the bending plate. You can then install the suitable accessories for the type of work you want to make.

The damaged electrical cables should be urgently replaced.

Unplug the machine from the electricity and never manipulate nor operate on the mechanical nor electrical elements of the machine while the engine is on.

Never use the machine for purposes other than those it has been designed for.

- **VERY IMPORTANT: Earth should always be connected** before switching on the machine.
- Use correct connection cable
- Check the electricity supply to the machine and make sure it is the same as indicated on the serial number plaque or sticker.
- Make sure the cable is secure from direct heat, oil, footfall.
- Don't use pressurised water to clean the machine as this may get into the electrical components.

**ATTENTION: You are to follow all safety recommendations mentioned in the present user manual and comply with all labour risks prevention norms in every location.**

**SIMA, S.A. is not responsible for the consequences possibly generated but the inadequate use of the bending or the combined (bending/cutting) machine.**

## 15. WARRANTY

SIMA, S.A. the manufacturer of light machinery for construction possesses a net of technical services "SERVI-SIMA".

Repairs under warranty made by SERVI-SIMA are subject to some strict condition to guaranty a high quality and service.

SIMA S. A. guarantees all its products against any manufacturing defect; to take into account the conditions stated in the attached document "WARRANTY CONDITIONS". The latter would cease in case of failure to comply with the established payment terms. SIMA S.A. reserves its right to bring modifications and changes to its products without prior notice.

## 16. DECLARATIONS ON NOISE

The acoustic levels emitted by the MACHINE are inferior to 70 dB (A)

## 17. DECLARATIONS ON MECHANIAL VIBRATIONS

The machine does not present any source of mechanical vibrations that cause risks to the health or safety of the operator.

## 18. SPARE PARTS

The spare parts for the bending and combined machines, manufactured by SIMA, S.A. are to be found in the spare parts plan, attached to this manual.

To order any spare part, please contact our alter-sales service clearly indicating the serial number of the machine, **model, manufacturing number and year of manufacturing that show on the serial number plaque or sticker.**

## 19. ENVIRONMENT PROTECTION



Raw materials have to be collected instead of throwing away residuals. Instruments, accessories, fluids and packages have to be sent into specific places for ecological reuse. Plastic components are marked for selective recycling.



**R.A.E.E. Residuals arising of electrical and electronic instruments have to be stored into specific places for selective collection.**



SOCIEDAD INDUSTRIAL DE MAQUINARIA ANDALUZA, S.A.

POL. IND. JUNCARIL, C/ALBUÑOL, PARC. 250

18220 ALBOLOTE (GRANADA)

Tel.: 34 - 958-49 04 10 - Fax: 34 - 958-46 66 45

FABRICACIÓN DE MAQUINARIA PARA LA CONSTRUCCIÓN

ESPAÑA